



# 625A

---

---

**TECHNICAL SPECIFICATION  
FOR  
ALKALINE MANGANESE DIOXIDE BUTTON CELL**

DATE: 2005/1/1

SPEC. NO.: ES-625A

REVISION: 2005B

---

---

**GOLDEN POWER CORPORATION (HK) LTD.**

Flat C, 20/F, Block 1, Tai Ping Industrial Centre, 57 Ting Kok Road, Tai Po, N.T., Hong Kong

Tel: (852) 3125 2288 Fax: (852) 3125 2000 / (852) 3125 2001

E-mail: [battery@goldenpower.com](mailto:battery@goldenpower.com) Web Page: <http://www.goldenpower.com>

---

*The Manufacturer reserves the right to modify product specification and data stated herein without prior notice*



**8. Safety Characteristics**

| Item                          | Condition               | Period   | Requirement                            | Acceptance Standard |
|-------------------------------|-------------------------|----------|--|---------------------|
| Short Circuit Characteristics | At temperature 20+/-2°C | 24 hours | There shall be no explosion of battery | N=9; Ac=0; Re=1     |

**9. Marking**

The following markings will be printed, stamped or impressed on the body of the battery:

- (1) Designation : 625A
- (2) Manufacturer's name or abbreviation **"Golden Power Logo"** 
- (3) Polarity marking : '625A' on the cathode can

**10. Caution for use**

- (1) Since the battery is not manufactured for recharging, there are risks of electrolyte leakage or causing damage to the device if the battery is charged.
- (2) The battery shall be installed with its "+" and "-" polarity in correct position, otherwise may cause short-circuit.
- (3) Short-circuiting, heating, disposing of into fire and disassembling the battery are prohibited.
- (4) Battery cannot be forced discharged, which lead to excess gassing and, may result in bulging, leakage and de-crimping of cap.
- (5) New and used batteries cannot be used at the same time, when replaced batteries recommend to replace all and with the same brand type.
- (6) Exhausted batteries should be removed from compartment to prevent over-discharge, which cause leakage \_damage to the device.
- (7) Direct soldering is not allowed, which will damage the battery.
- (8) Battery should be kept out of the reach of children to prevent swallow, in case of accident should contact physician at once.

**11. Shelf Life** 1 year after delivery under proper storage conditions.  
(Temperature: 20+/-2°C; Relative humidity: 65+/-20%RH)

90% of the capacity will be maintained after 12 months storage

**12. Discharge Curves** (Condition: Test temperature 20+/-2°C)

Discharge Method: 2.7kΩ 24 hours/day (Figure 1)

**13. Battery Dimension** Ref to Drawing DWG-S002

**14. Battery Structure** Ref to Drawing DWG-S002

# GOLDEN POWER CORPORATION (HK) LTD.

Figure 1: 625A DISCHARGE CURVE

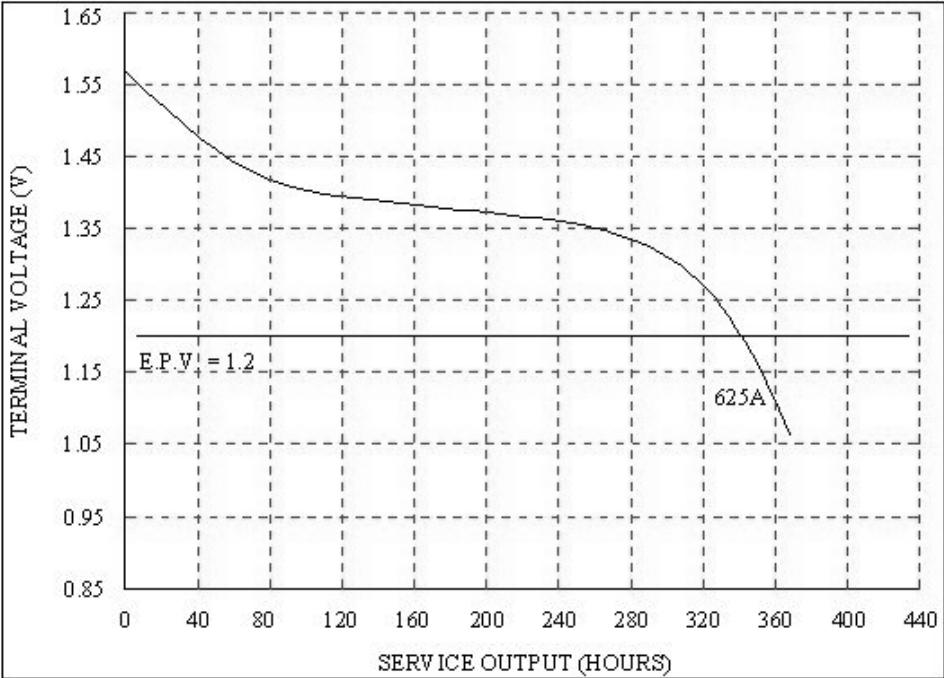

DISCHARGE METHOD: 2.7k ohm ; 24 hours/day

TEMPERATURE: 20+/-2°C

# 625A DIMENSIONS & STRUCTURE

Dimensions ( in mm ) :

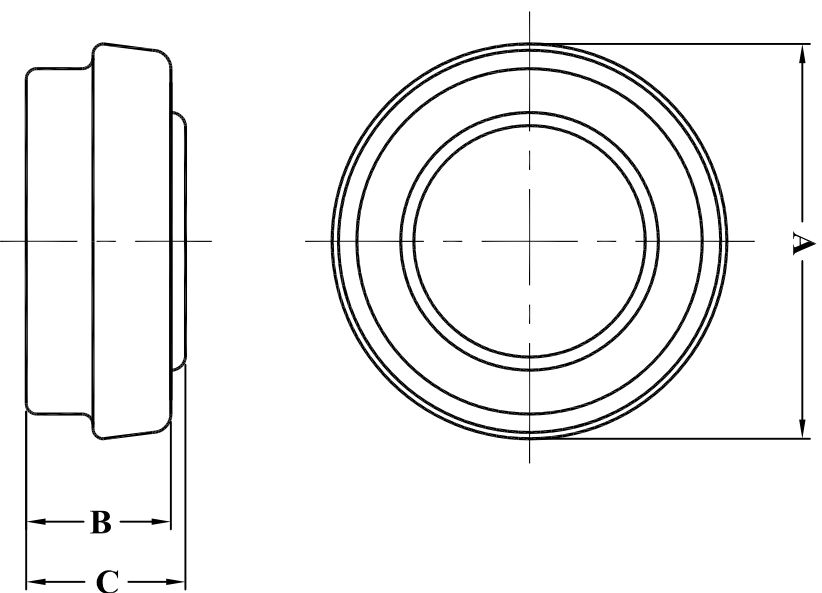

| Dimensions | Specification                       |
|------------|-------------------------------------|
| A          | $\varnothing 15.00^{+0.00}_{-0.20}$ |
| B          | $5.70^{+0.00}_{-0.30}$              |
| C          | $6.20^{+0.00}_{-0.40}$              |

Structure :

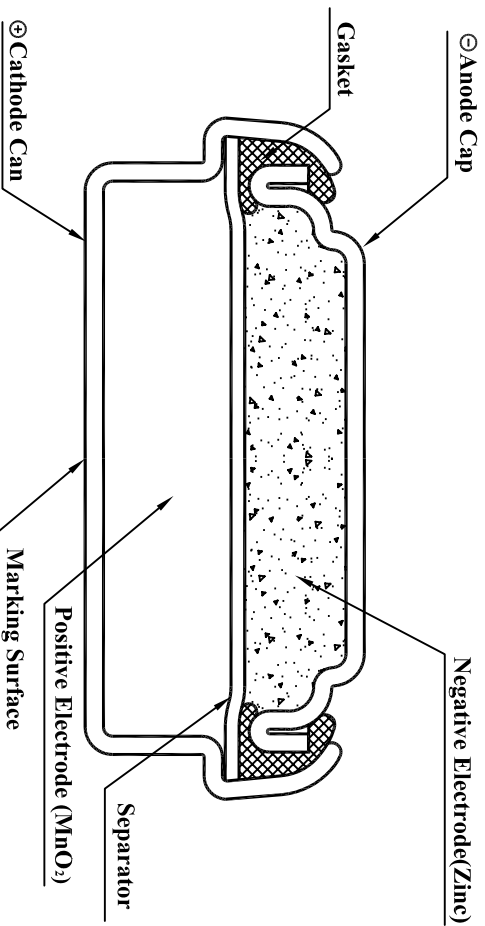

DWG-S-002