

379S

**TECHNICAL SPECIFICATION
FOR
SILVER OXIDE BUTTON CELL**

Approved	
General Manager:	 Date:

Date: 2007/04/02
SPEC. No.: GP001-379S
REVISION: 01

GOLDEN POWER CORPORATION (HK) LTD.

Flat C, 20/F, Block 1, Tai Ping Industrial Centre, 57 Ting Kok Road, Tai Po, N.T. Hong Kong.
Tel: (852) 3125 2288 Fax: (852) 3125 2000 / (852) 3125 2001
E-mail: battery@goldenpower.com Web Page: <http://www.goldenpower.com>

The Manufacturer reserves the right to modify product specification and data stated herein without prior notice.

1. Scope

This specification is applicable to Golden Power's Silver Oxide Button Cell

Model No.: 379S.

1.1 Designations

Golden Power: 379S IEC: SR63 Others: ---
 JIS: SR63 ANSI: ---

1.2 Reference Document

- IEC 60086-1 (2000-11) - Primary Batteries - Part 1: General
- IEC 60086-2 (2004-02) - Primary Batteries - Part 2: Physical and Electrical Specification
- IEC 60086-5 (2005-04) - Primary Batteries - Part 5: Safety of batteries with aqueous electrolyte

2. Chemical System

Zinc-Silver Oxide (Sodium Hydroxide Electrolyte and/or Potassium Hydroxide Electrolyte)

3. Nominal Voltage: 1.55V

4. Average Weight: 0.21g

5. Nominal Capacity

8mAh (continuous discharge at 20 ± 2°C under 47kΩ discharge load for 24hrs/day to 1.2V end-point voltage)

6. Electrical Characteristics

Test Conditions: 47kΩ ± 0.5% load resistance, measuring time 0.3 seconds, temperature at 20 ± 2°C, tested within 30 days after delivery.

	Off-load voltage (V)	On-load voltage (V)	Test Specification
New Battery	1.56	1.55	MIL-STD-105E, Class II, Double Sampling, AQL=0.4

7. Service Output

Test Conditions: Temperature at 20 ± 2°C, tested within 30 days after delivery.

Standard	Discharge Condition			Average Minimum Discharge Time	
	Discharge load	Daily discharge time	End Point Voltage (V)	New Battery	After 12 mths. at room temp.
IEC	47kΩ	24 hrs	1.2	260 hrs	235 hrs

Satisfaction Standard:

- (1) 9 pieces of battery will be tested for each discharging standard.
- (2) The result of the average discharging time from each discharging standard shall be equal to or more than the average minimum time requirement; and no more than one battery has a service output less than 80% of the specified requirement.
- (3) One re-test is allowed to confirm the previous result.

8. Safety Characteristics

Item	Condition	Period	Requirements	Acceptance Standard
Short circuit Characteristics	Temp.: 20 ±2°C	24 hours	There shall be no explosion of battery	N=9, Ac=0, Re=1

9. Marking

The following markings will be printed, stamped or impressed on the body of the battery:

- (1) Designation: 379S.
- (2) Manufacturer's name or abbreviation : "Golden Power Logo" 
- (3) Polarity Marking: '379S+ BUTTON CELL' on the cathode can

10. Caution for Use

- (1) Since the battery is not manufactured for recharging, there are risks of electrolyte leakage or causing damage to the device if the battery is charged.
- (2) The battery shall be installed with its "+" and "-" polarity in correct position, otherwise may cause short-circuit.
- (3) Short-circuiting, heating, disposing of into fire and disassembling the battery are prohibited.
- (4) Battery cannot be forced discharge, which lead to excess internal gas generation and, may result in bulging, leakage and de-crimping of cap.
- (5) New and used batteries cannot be used at the same time, when replaced batteries recommend to replace all and with the same brand type.
- (6) Exhausted batteries should be removed from compartment to prevent over-discharge, which cause leakage & damage to the device.
- (7) Direct soldering is not allowed, which will damage the battery.
- (8) Battery should be kept out of the reach of children to prevent swallow, in case of accident should contact physician at once.
- (9) The battery should not be dismantled and deformed.

11. Shelf Life

1 year after delivery under proper storage conditions.

(Temperature: $20 \pm 2^{\circ}\text{C}$; Relative humidity: $65 \pm 20\%$ RH)

90% of the capacity will be maintained after 1 year storage.

12. Discharge Curves (Condition: Test temperature $20 \pm 2^{\circ}\text{C}$)

Discharge Method: $47\text{k}\Omega$, 24hours/day (Figure 1)

13. Battery Dimension (Refer to Drawing DWG-S-002)**14. Battery Structure** (Refer to Drawing DWG-S-002)

Golden Power Corporation (HK) Ltd.

Figure 1: 379S DISCHARGE CURVE

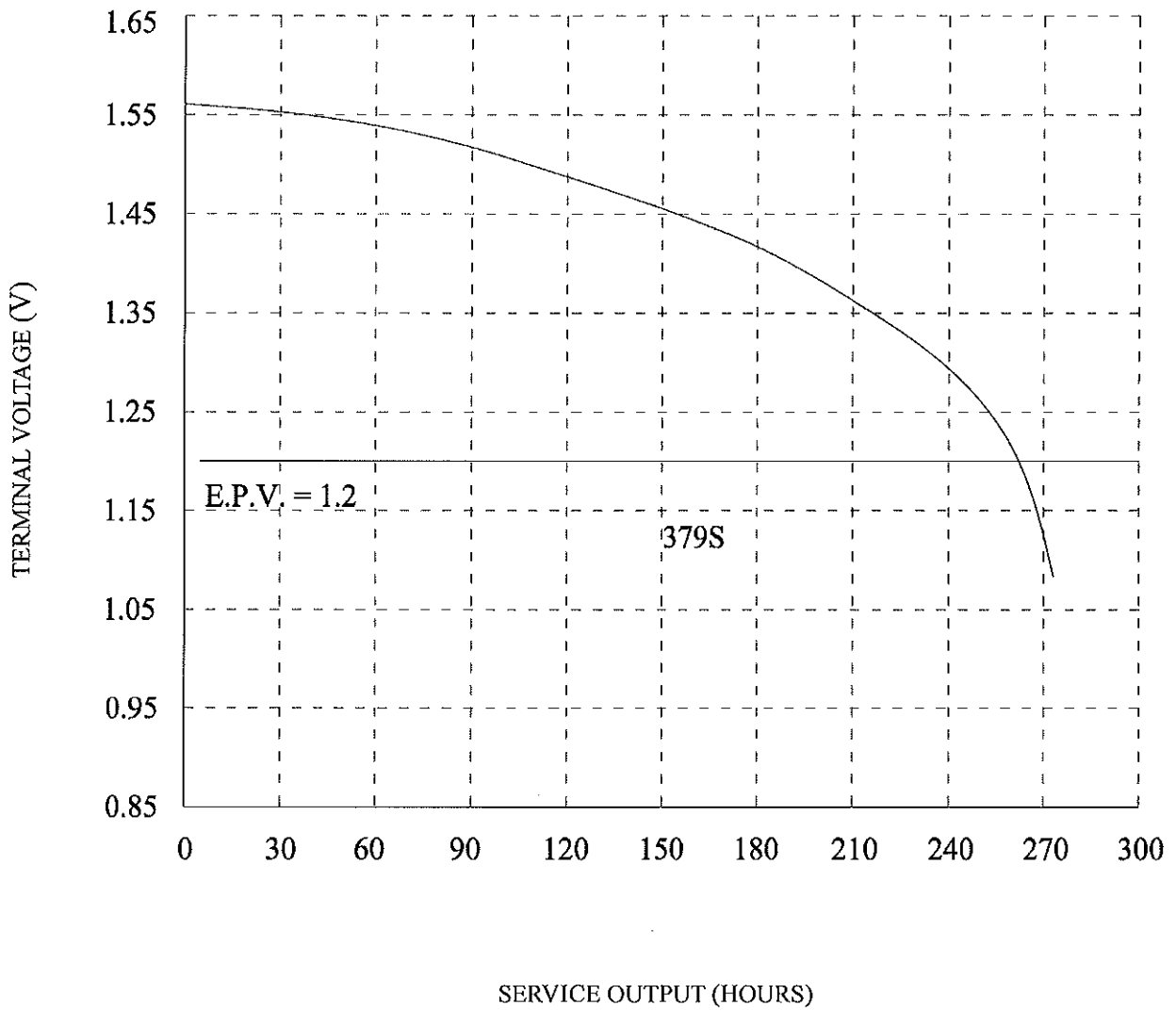

DISCHARGE METHOD: 47kΩ; 24hours/day
TEMPERATURE: 20 ±2°C

379S DIMENSIONS & STRUCTURE

Dimensions (in mm) :

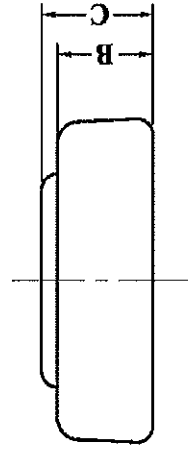
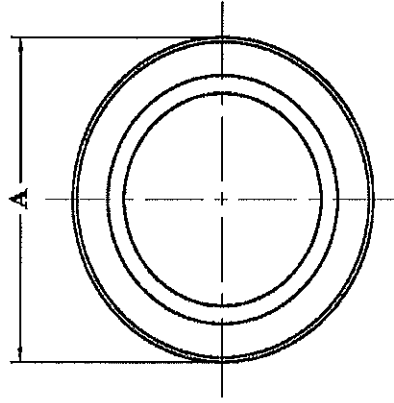

Dimensions	Specification
A	$\varnothing 5.80^{+0.00}_{-0.25}$
B	$1.85^{+0.00}_{-0.25}$
C	$2.15^{+0.00}_{-0.25}$

Structure :

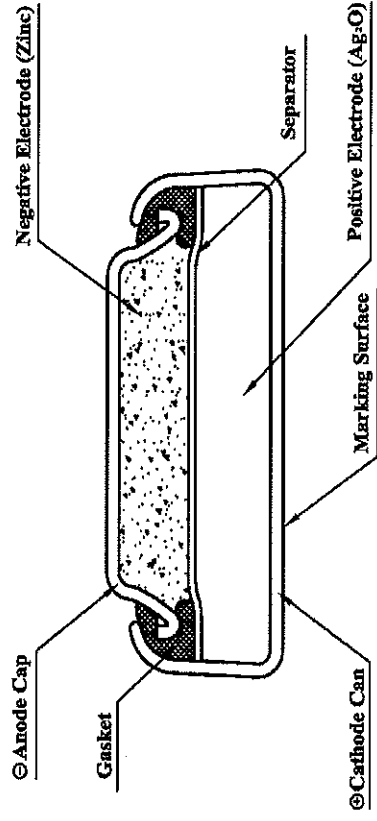

DWG-S-002