

# 393S

---

## TECHNICAL SPECIFICATION FOR SILVER OXIDE BUTTON CELL

<b>Approved</b>	
General Manager:	Date:

Date: 2007/04/02  
SPEC. No.: GP001-393S  
REVISION: 01

---

### GOLDEN POWER CORPORATION (HK) LTD.

Flat C, 20/F, Block 1, Tai Ping Industrial Centre, 57 Ting Kok Road, Tai Po, N.T. Hong Kong.  
Tel: (852) 3125 2288 Fax: (852) 3125 2000 / (852) 3125 2001  
E-mail: battery@goldenpower.com Web Page: <http://www.goldenpower.com>

---

*The Manufacturer reserves the right to modify product specification and data stated herein without prior notice.*



Satisfaction Standard:

- (1) 9 pieces of battery will be tested for each discharging standard.
- (2) The result of the average discharging time from each discharging standard shall be equal to or more than the average minimum time requirement; and no more than one battery has a service output less than 80% of the specified requirement.
- (3) One re-test is allowed to confirm the previous result.

**8. Safety Characteristics**

Item	Condition	Period	Requirements	Acceptance Standard
Short circuit Characteristics	Temp.: 20 ±2°C	24 hours	There shall be no explosion of battery	N=9, Ac=0, Re=1

**9. Marking**

The following markings will be printed, stamped or impressed on the body of the battery:

- (1) Designation: 393S.
- (2) Manufacturer's name or abbreviation : "Golden Power Logo" 
- (3) Polarity Marking: '393S+ BUTTON CELL' on the cathode can

**10. Caution for Use**

- (1) Since the battery is not manufactured for recharging, there are risks of electrolyte leakage or causing damage to the device if the battery is charged.
- (2) The battery shall be installed with its "+" and "-" polarity in correct position, otherwise may cause short-circuit.
- (3) Short-circuiting, heating, disposing of into fire and disassembling the battery are prohibited.
- (4) Battery cannot be forced discharge, which lead to excess internal gas generation and, may result in bulging, leakage and de-crimping of cap.
- (5) New and used batteries cannot be used at the same time, when replaced batteries recommend to replace all and with the same brand type.
- (6) Exhausted batteries should be removed from compartment to prevent over-discharge, which cause leakage & damage to the device.
- (7) Direct soldering is not allowed, which will damage the battery.
- (8) Battery should be kept out of the reach of children to prevent swallow, in case of accident should contact physician at once.
- (9) The battery should not be dismantled and deformed.

**11. Shelf Life**

1 year after delivery under proper storage conditions.

(Temperature:  $20 \pm 2^{\circ}\text{C}$ ; Relative humidity:  $65 \pm 20\%$  RH)

90% of the capacity will be maintained after 1 year storage.

**12. Discharge Curves** (Condition: Test temperature  $20 \pm 2^{\circ}\text{C}$ )

Discharge Method:  $15\text{k}\Omega$ , 24hours/day (Figure 1)

**13. Battery Dimension** (Refer to Drawing DWG-S-002)**14. Battery Structure** (Refer to Drawing DWG-S-002)

# Golden Power Corporation (HK) Ltd.

Figure 1: 393S DISCHARGE CURVE

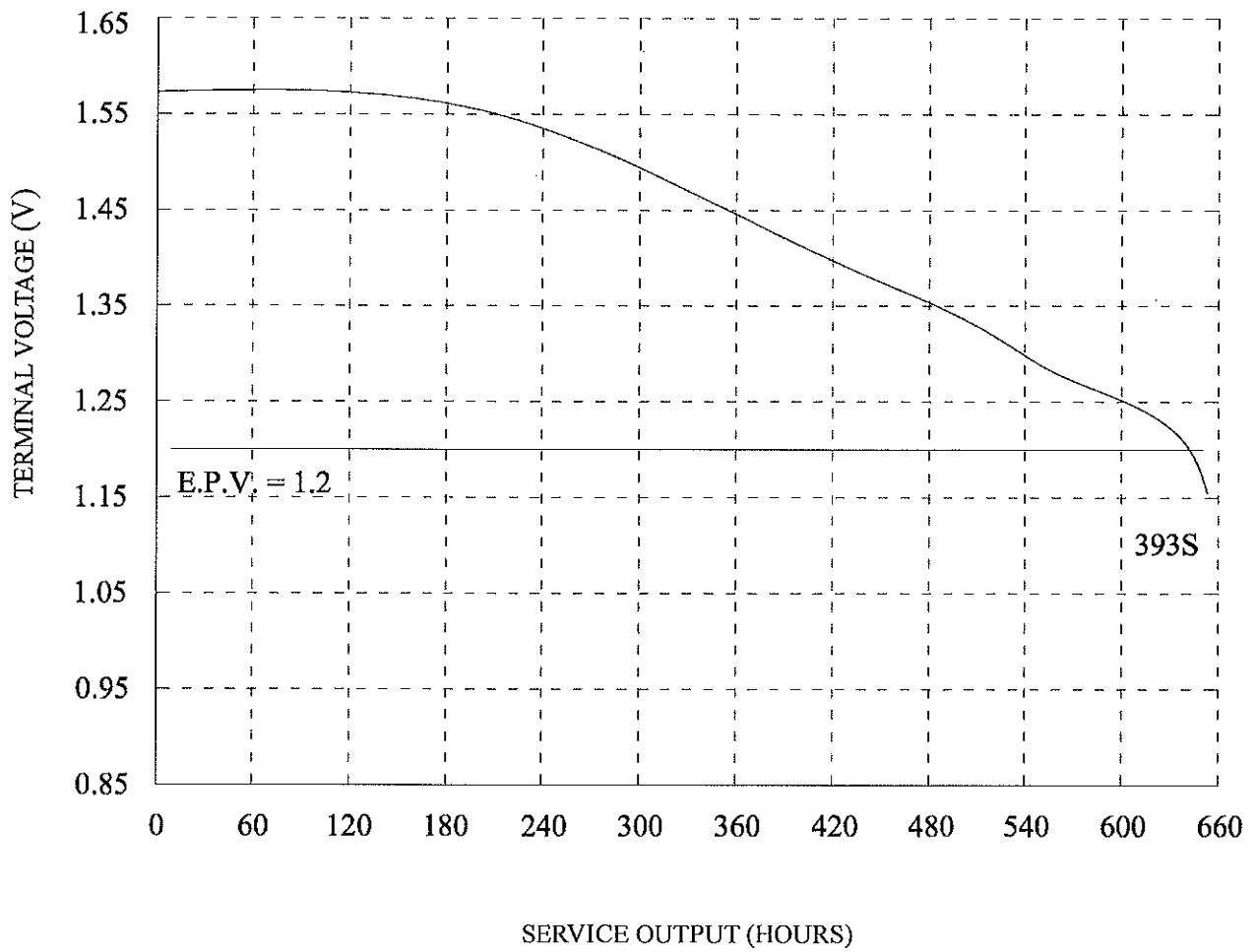

DISCHARGE METHOD: 15k $\Omega$ ; 24hours/day  
TEMPERATURE: 20  $\pm$ 2 $^{\circ}$ C

# 393S DIMENSIONS & STRUCTURE

Dimensions ( in mm ) :

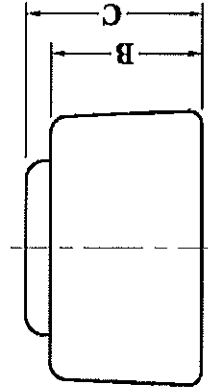
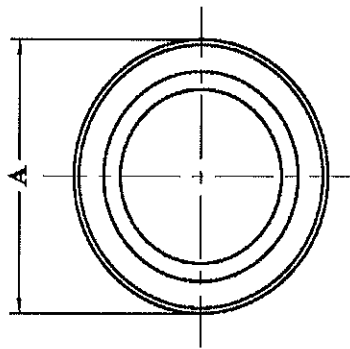

Dimensions	Specification
A	$\varnothing 7.90^{+0.00}_{-0.35}$
B	$4.77^{+0.00}_{-0.25}$
C	$5.40^{+0.00}_{-0.40}$

Structure :

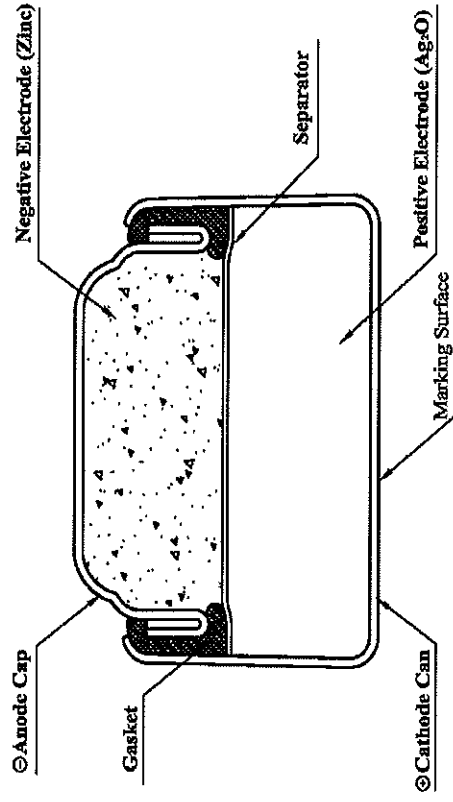

DWG-S-002