

394X

**TECHNICAL SPECIFICATION
FOR
SUPER SILVER OXIDE BUTTON CELL**

Approved		
General Manager:		Date:

Date: 2007/04/02
SPEC. No.: GP001-394X
REVISION: 01

GOLDEN POWER CORPORATION (HK) LTD.

Flat C, 20/F, Block 1, Tai Ping Industrial Centre, 57 Ting Kok Road, Tai Po, N.T. Hong Kong.
Tel: (852) 3125 2288 Fax: (852) 3125 2000 / (852) 3125 2001
E-mail: battery@goldenpower.com Web Page: <http://www.goldenpower.com>

The Manufacturer reserves the right to modify product specification and data stated herein without prior notice.

Satisfaction Standard:

- (1) 9 pieces of battery will be tested for each discharging standard.
- (2) The result of the average discharging time from each discharging standard shall be equal to or more than the average minimum time requirement; and no more than one battery has a service output less than 80% of the specified requirement.
- (3) One re-test is allowed to confirm the previous result.

8. Safety Characteristics

Item	Condition	Period	Requirements	Acceptance Standard
Short circuit Characteristics	Temp.: 20 ±2°C	24 hours	There shall be no explosion of battery	N=9, Ac=0, Re=1

9. Marking

The following markings will be printed, stamped or impressed on the body of the battery:

- (1) Designation: 394X.
- (2) Manufacturer's name or abbreviation : "Golden Power Logo" 
- (3) Polarity Marking: '394X+ BUTTON CELL' on the cathode can

10. Caution for Use

- (1) Since the battery is not manufactured for recharging, there are risks of electrolyte leakage or causing damage to the device if the battery is charged.
- (2) The battery shall be installed with its "+" and "-" polarity in correct position, otherwise may cause short-circuit.
- (3) Short-circuiting, heating, disposing of into fire and disassembling the battery are prohibited.
- (4) Battery cannot be forced discharge, which lead to excess internal gas generation and, may result in bulging, leakage and de-crimping of cap.
- (5) New and used batteries cannot be used at the same time, when replaced batteries recommend to replace all and with the same brand type.
- (6) Exhausted batteries should be removed from compartment to prevent over-discharge, which cause leakage & damage to the device.
- (7) Direct soldering is not allowed, which will damage the battery.
- (8) Battery should be kept out of the reach of children to prevent swallow, in case of accident should contact physician at once.
- (9) The battery should not be dismantled and deformed.

11. Shelf Life

1 year after delivery under proper storage conditions.

(Temperature: $20 \pm 2^{\circ}\text{C}$; Relative humidity: $65 \pm 20\%$ RH)

90% of the capacity will be maintained after 1 year storage.

12. Discharge Curves (Condition: Test temperature $20 \pm 2^{\circ}\text{C}$)

Discharge Method: $15\text{k}\Omega$, 24hours/day (Figure 1)

13. Battery Dimension (Refer to Drawing DWG-S-002)**14. Battery Structure** (Refer to Drawing DWG-S-002)

Golden Power Corporation (HK) Ltd.

Figure 1: 394X DISCHARGE CURVE

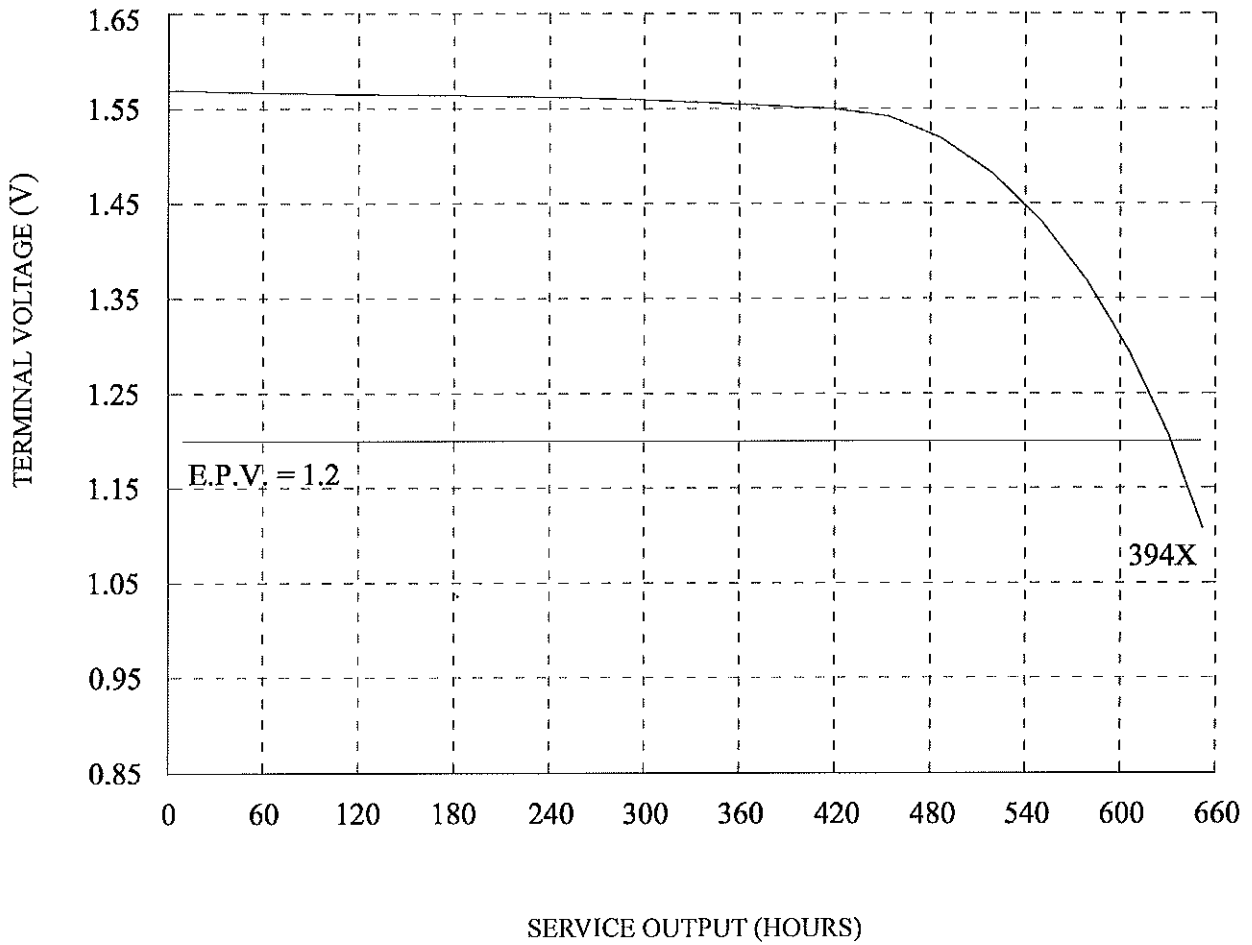

DISCHARGE METHOD: 15k Ω ; 24hours/day
TEMPERATURE: 20 \pm 2 $^{\circ}$ C

394X DIMENSIONS & STRUCTURE

Dimensions (in mm) :

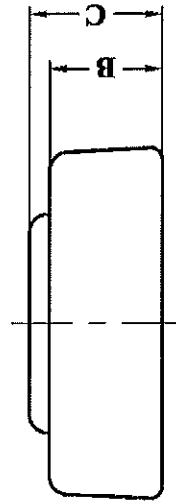
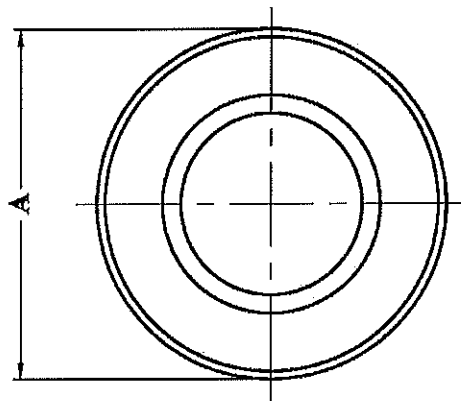

Dimensions	Specification
A	$\varnothing 9.50^{+0.00}_{-0.10}$
B	$3.05^{+0.00}_{-0.25}$
C	$3.60^{+0.00}_{-0.25}$

Structure :

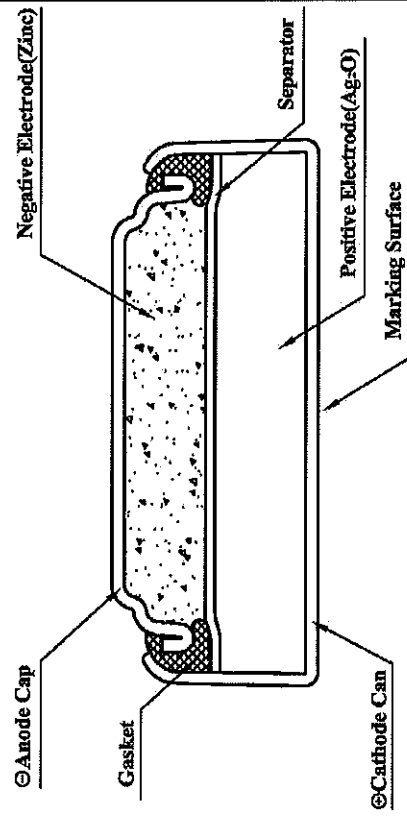

DWG-S-002