



# SR521SW

---

---

## TECHNICAL SPECIFICATION FOR SUPER PLUS SILVER OXIDE BUTTON CELL

DATE: 2005/1/1

SPEC. NO.: TES-SR521SW

REVISION: 2005B

---

---

### **GOLDEN POWER CORPORATION (HK) LTD.**

Flat C, 20/F, Block 1, Tai Ping Industrial Centre, 57 Ting Kok Road, Tai Po, N.T., Hong Kong

Tel: (852) 3125 2288 Fax: (852) 3125 2000 / (852) 3125 2001

E-mail: [battery@goldenpower.com](mailto:battery@goldenpower.com) Web Page: <http://www.goldenpower.com>

---

*The Manufacturer reserves the right to modify product specification and data stated herein without prior notice*

**1. Scope**

This Specification is applicable to Golden Power's Super Plus Silver Oxide Button Cell Model No.:SR521SW

**1.1 Designations**

Golden Power: SR521SW                      IEC: SR63                      Others: 379  
 JIS: SR63    ANSI: ---

**1.2 Reference Document**

IEC 60086-1 (2000-11) --- Primary Batteries - Part 1: General  
 IEC 60086-2 (2001-10) --- Primary Batteries - Part 2: Physical and electrical specification  
 IEC 60086-5 (2000-07) --- Primary Batteries - Part 5: Safety of batteries with aqueous electrolyte

**2. Chemical System**

Zinc-Silver Oxide (Sodium Hydroxide Electrolyte and/or Potassium hydroxide electrolyte)

**3. Nominal Voltage:**     1.55 V

**4. Average Weight :**     0.26 g

**5. Nominal Capacity**

16mAh (Continuous discharge at 20+/-2°C under 47kΩ discharge load to 1.2V end-point voltage)

**6. Electrical Characteristics**

Test conditions:    47kΩ+/-0.5% load resistance, measuring time 0.3 seconds,  
 temperature at 20+/-2 °C, tested within 30 days after delivery.

	Off-Load Voltage (V)	On-Load Voltage (V)	Test Specification
New Battery	1.56	1.55	MIL-STD 105E, Class II, Double Sampling, AQL=0.4

**7. Service Output**

Condition: Test temperature 20 +/- 2°C, tested within 30 days after delivery

Standard	Discharge Condition			Average Minimum Discharge Time	
	Discharge Load	Discharge Time	E.P.V. (V)	New Battery	After 12 mths. at room temperature
IEC	47kΩ	24 hr	1.2	480 hr	430 hr

Satisfaction Standard:

- 1) 9 pieces of battery will be tested for each discharging standard.
- 2) The result of the average discharging time from each discharging standard shall be equal to or more than the average minimum time requirement; and no more than one battery has a service output less than 80% of the specified requirement.
- 3) One re-test is allowed to confirm the previous result

**8. Safety Characteristics**

Item	Condition	Period	Requirement	Acceptance Standard
Short Circuit Characteristics	At temperature 20+/-2°C	24 hours	There shall be no explosion of battery	N=9; Ac=0; Re=1

**9. Marking**

The following markings will be printed, stamped or impressed on the body of the battery:

- (1) Designation : SR521SW
- (2) Manufacturer's name or abbreviation **"Golden Power Logo"** 
- (3) Polarity marking : 'SR521SW' on the cathode can

**10. Caution for use**

- (1) Since the battery is not manufactured for recharging, there are risks of electrolyte leakage or causing damage to the device if the battery is charged.
- (2) The battery shall be installed with its "+" and "-" polarity in correct position, otherwise may cause short-circuit.
- (3) Short-circuiting, heating, disposing of into fire and disassembling the battery are prohibited.
- (4) Battery cannot be forced discharged, which lead to excess gassing and, may result in bulging, leakage and de-crimping of cap.
- (5) New and used batteries cannot be used at the same time, when replaced batteries recommend to replace all and with the same brand type.
- (6) Exhausted batteries should be removed from compartment to prevent over-discharge, which cause leakage \_damage to the device.
- (7) Direct soldering is not allowed, which will damage the battery.
- (8) Battery should be kept out of the reach of children to prevent swallow, in case of accident should contact physician at once.

**11. Shelf Life** 1 year after delivery under proper storage conditions.  
(Temperature: 20+/-2°C; Relative humidity: 65+/-20%RH)

90% of the capacity will be maintained after 12 months storage

**12. Discharge Curves** (Condition: Test temperature 20+/-2°C)

Discharge Method: 47kΩ 24 hours/day (Figure 1)

**13. Battery Dimension** Ref to Drawing DWG-S002

**14. Battery Structure** Ref to Drawing DWG-S002

# GOLDEN POWER CORPORATION (HK) LTD.

Figure 1: SR521SW DISCHARGE CURVE

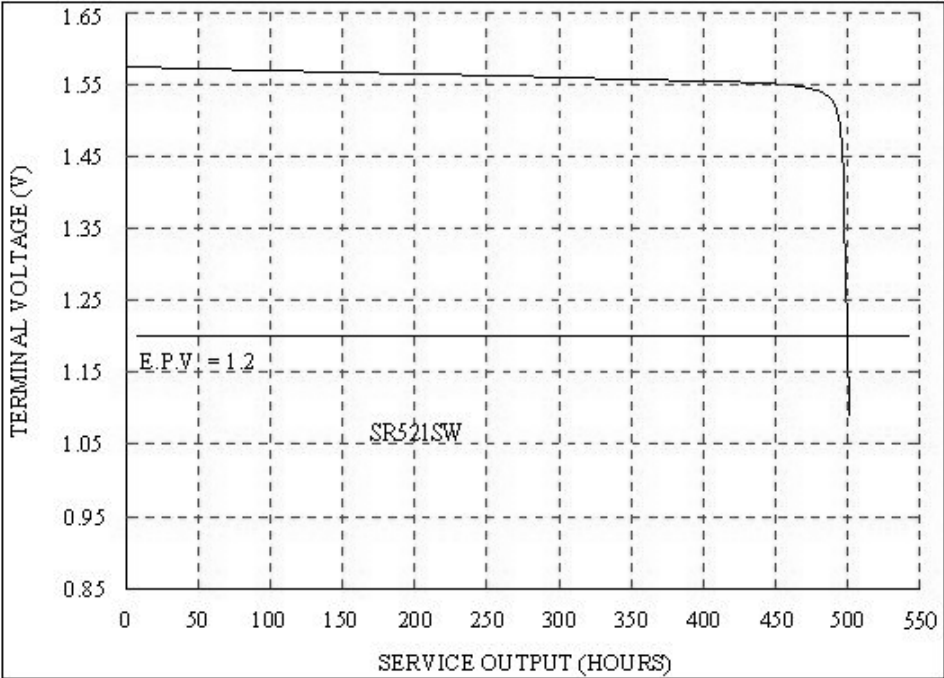

DISCHARGE METHOD: 47k ohm ; 24 hours/day  
TEMPERATURE: 20+/-2°C

# SR521SW DIMENSIONS & STRUCTURE

Dimensions ( in mm ) :

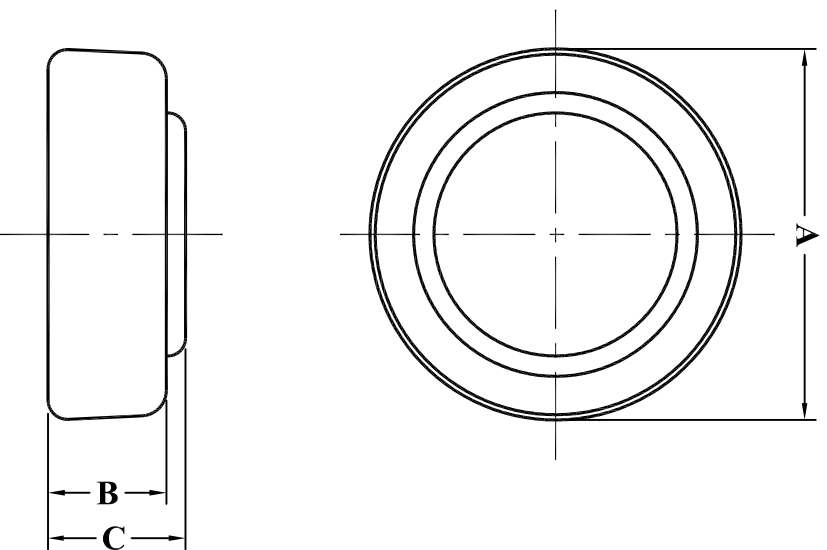

Dimensions	Specification
<b>A</b>	$\varnothing 5.80^{+0.00}_{-0.25}$
<b>B</b>	$1.85^{+0.00}_{-0.25}$
<b>C</b>	$2.15^{+0.00}_{-0.25}$

Structure :

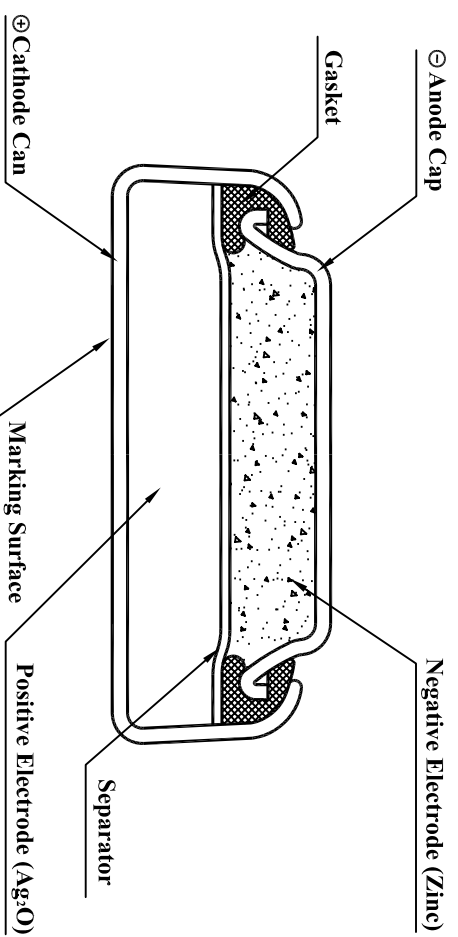

DWG-S-002